

Resato

HIGH PRESSURE TECHNOLOGY



AUTOMATIC HOSE TEST UNIT, TYPE SPU

Pressure range from 1 up to 10,000 bar
User-friendly touch panel operation

INTRODUCTION

Quality control of defects in materials and assembly is always required for assembly and repair of hoses. Hoses must be tested under pressure and test data must be made visible. In order to do this in a safe, quick and visible manner, Resato has developed the automatic Hose Test Unit, type SPU.

The ergonomically designed unit with its integrated spacious stainless steel test compartment is ready to use for execution of pressure tests on hoses.

Pipes, pressure vessels, pumps, valves, hydraulic components and manifolds can also be tested for defects in material or assembly. Heavy test objects can be placed inside the test compartment on a (Euro)pallet, if necessary.

In order to safely and quickly execute pressure tests in spite of the enormous diversity in hoses and connections, we assemble every unit to specification. The unique modular and flexible construction of the SPU-unit allows us to build a test system with a choice from a wide range of options to meet your specific demands. Refer to the options table to determine which options are required for the specific system setup you need.

The Hose Test Unit can be fitted with a maximum of five air-driven Resato high-pressure pumps for test pressures from 1 to 5000 bar. For test pressures higher than 5000 bar a Resato air-driven pump is used to drive a Resato hydraulic intensifier pump or intensifier. Each pump range will have its own electronic pressure transmitter to ensure that the specified measurement accuracy can be achieved over the whole pressure range. This accuracy also guarantees a good repeatability for each test procedure ("Test job").

The SPU can either be connected to the water mains, or to an external reservoir. As an option, the SPU can be supplied with an integrated fluid tank of 100 liters. Tap water, water with corrosion inhibitor, oil or an emulsion, to be used as a test medium. Other media, including various types of gases, can be used after consultation with Resato.

OPERATION

The hose is placed in the test compartment and connected. A test can be selected on the touch panel, or a new test can be defined. You can start the test by pressing a button on the touch panel. The test will then be automatically executed; no intervention is required in the meantime.

After the hose has been prefilled and de-aired, pressure build-up starts. The pump stops automatically when the selected test pressure is reached. The stabilization time starts. The hose will expand because of the high pressure and the pressure will drop slightly. During the stabilization time this pressure drop is compensated by the pump(s). Then the pump(s) stop(s), the hose is isolated from the pump(s) and the actual test time starts. During this test time a possible leak in the hose will be measured by means of the electronic pressure sensor. During testing progress is visible on the touch panel. In the meantime a new test can be prepared while all essential functions of the test in progress can still be monitored. After the test has been completed, the pressure is released and the hose is emptied. Now the hose can be disconnected.

FEATURES

The SPU-hose test unit features:

- Ergonomic, safe and user-friendly design
- User-friendly Resato hose test software
- 15" touch panel
- Quick serial testing through preset test pressure
- Low noise level
- Suitable for various test mediums such as tap water, oil, an emulsion of both and many other liquids and gases.
- Spacious test compartment; use of (Euro)pallet is possible
- Modular and flexible design makes it possible to choose a unit in accordance with your specific requirements
- Each pump range is supplied with an electronic pressure transmitter for accurate measurement over the full test pressure range
- All main components made by Resato
- Fully traceable material for all high-pressure parts and components

EASY AND USER-FRIENDLY OPERATION WITH RESATO HOSE TEST SOFTWARE

Resato has paid a lot of attention to user-friendly operation. A clear and intuitive user interface with a “Test job manager” helps you to execute a search for a specific characteristic in previously executed tests. You can execute a search on for example hose type, customer name, certificate number, date or serial number. Previously executed test parameters can also be copied with the “Test job manager” to be used again; a new certificate number is automatically assigned in the process. It is also possible to change customer name, hose type etc with a previously executed test to allow you to do a new test immediately. With series tests a single “repeat” action on the touch panel allows you to repeat a test. The values for stabilization time and test time and all other test parameters are standard set to the last selected value. However, these can be changed as desired within seconds. Executed and saved tests can be printed as a certificate on the integrated printer. Tests that have been executed can be saved on the PC of the SPU or on the company intranet.

An optional software package designed by Resato offers the possibility to prepare work for testing on a separate PC in a network environment. A network environment can consist of a single PC or Laptop that is connected to the SPU. The extensive database facilities of an existing ERP system can be used. All tests to be executed can be prepared (by feeding data from the ERP system) to ensure that the machine starts testing after a single tap on the touch screen. Another possibility is to use the optional barcode reader to identify a barcode-labeled hose or series of hoses, and upload all relevant data for the “Test job” from the database in the “Test queue” of the “Test job manager”. All test certificates can first be stored locally on the SPU or on a predefined location on the Intranet to be printed all at a specified time by way of a network printer. The optional software package also offers the possibility to adapt the layout of the certificate to your wishes.

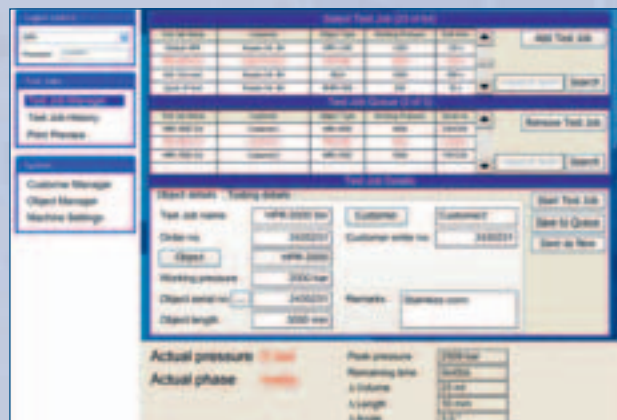

TECHNICAL DESCRIPTION

Process controller:

A compact real-time and multi-threading kernel (operating system) with extremely short cycle times. No unwanted intrusions from the Windows XP embedded operating system and also protected against other unwanted intrusions such as viruses over network connections. The controller has been tested extensively in environments varying in temperature from -5 to + 60 degrees C.

Resato hose test software:

The Resato hose test software runs in a windows XP embedded environment on a fanless industrial PC, which can communicate over Ethernet networks if required. Operation and visualization by way of a 15" color touch screen.

High-pressure pump:

The Resato high pressure pump is controlled by a maximum of 7 bar compressed air or nitrogen. Because of the air drive section with its unique air-controlled reciprocating movement, the pump is very quiet and reliable. This unique air drive section, with low friction and almost no stick-slip, facilitates very accurate pressure control by the process controller. The unique construction enables quick and easy replacement of seals. For that reason the Resato high-pressure pump has won worldwide fame for reliability in a wide range of applications.

High-pressure valves:

Reliable operation and long life cycle are combined with ergonomic design by use of air-operated Resato high-pressure valves.

High-pressure fittings:

Like the high-pressure pump and valves, the high-pressure fittings are of our own manufacture. For reasons of safety, high-pressure fittings with metallic seals and weep hole are used from 280 bar.

Electronic pressure transmitters:

- Pressure range: up to 10,000 bar
- Accuracy: 0.5% F.S.

Materials:

All main components such as the high-pressure valves, tubing, fittings, gauges and wetted parts of the pump are made of corrosion-resistant high tensile strength stainless steel alloys.

Resato uses only fully traceable materials for all high-pressure parts and components.

Certificates

The Resato SPU-unit is standard delivered with a test certificate for the unit and a calibration certificate for each pressure measuring instrument.

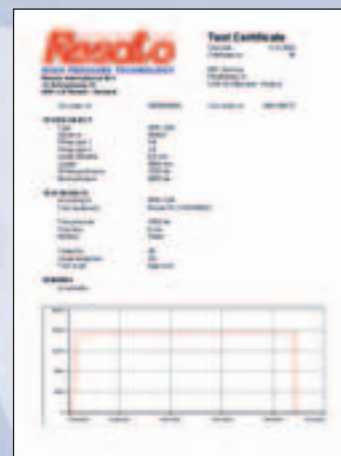

The test data must be made visible through a test certificate.



Quality control of defects in materials and assembly is the first priority.

SAFETY

The SPU-pressure test unit has the following standard provisions for safety:

- Automatic pressure release at opening of test compartment
- The door has impact-resistant polycarbonate windows
- The door is fitted with an integrated electronic lock
- Signal lamp for test status indication

OPTIONS PACKAGE

The automatic hose test unit, type SPU, can be supplied with the following options.

Burst Test Box:

With this option it is possible to perform burst tests up to 10,000 bar. The burst test box is made as a solid stainless construction which makes it possible to perform burst tests in a safe and accurate way. The burst test box can be removed from the test compartment. A special burst test certificate will be generated automatically as a single certificate or in a combined certificate with length, twisting and volumetric expansion measurement.

Length measurement:

This option allows you to measure the length change of a hose during pressurization. The change in length will be measured with an electronic transmitter which gives a signal to the computer. This option cannot be used during a burst test. A special length test certificate will be generated automatically (combined or separately).

Twisting measurement:

This option allows you to measure the twisting of a hose during pressurization. The hose twisting transmitter will give an output signal to the computer. This option cannot be used during a burst test. A special twisting certificate will be generated automatically (combined or separately).

Volumetric expansion measurement

This option is not included in the automatic hose test procedure. The hose to be tested is placed in a vertical position. The volumetric expansion is measured cumulatively in different pressure steps. Measuring is done by using a burette. Various burettes are available. The measured values have to be entered manually in the computer.

A special volumetric expansion certificate will be generated automatically (combined or separately).

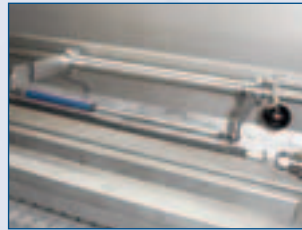

DIMENSIONS

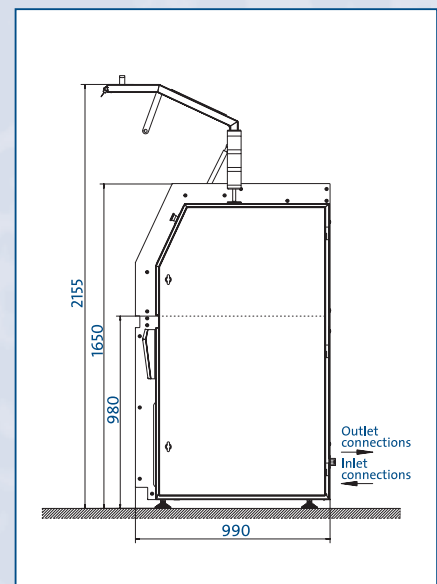
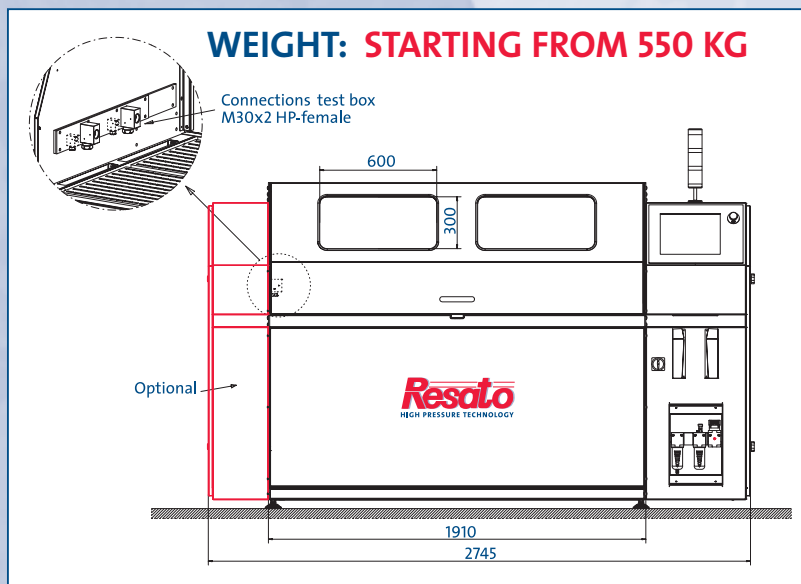

QUICK AND EFFICIENT SERVICE

To ensure optimal use of your test unit, Resato provides high quality service. All components for the SPU unit are our own manufacture.

All spare parts are kept in stock. Maintenance and calibration can be done in our factory or on location. Multidisciplinary technical service engineers take care of calibration, preventive maintenance, software updates, inspections and repairs.

EXAMPLES OF RESATO HIGH-PRESSURE COMPONENTS UP TO 14,000 BAR

Air-driven pumps and gas boosters

Hydraulically-driven pumps and gas boosters

Fittings

General-purpose valves

Check valves

Swivels

Hoses

Tubing

Pressure transducers

Rupture-disc safety devices

Quick connectors

EXAMPLES OF RESATO HIGH-PRESSURE EQUIPMENT AND SYSTEMS

Portable pressure-test systems

Test equipment for hoses (safety) valves, fittings etc.

Computer-controlled high-pressure test equipment

Autofrettage systems

Autoclaves

Custom-made test equipment

Water-jet cutting systems

High-pressure food preservation systems

PC data acquisition and recording systems

COMPANY PROFILE RESATO

Founded in 1985, Resato International B.V. is dedicated in the design and manufacture of high-pressure components and systems for pressures of up to 14,000 bar (200,000 psi).

At our modern manufacturing plant in Roden, The Netherlands, we have our own engineering and R&D departments as well as sophisticated production facilities. These enable us to furnish precisely the right component or system a client may need.



RESATO INTERNATIONAL BV

P.O. Box 30, 9300 AA Roden - Holland

1e Energieweg 13, 9301 LK Roden - Holland

Phone: (+31) 50 - 501 6877

Fax: (+31) 50 - 501 2402

E-mail: info@resato.com

Internet: www.resato.com

Please note that general data and specifications given in this brochure are subject to change without notice. Feel free to contact our sales department if you need more definite information.